

FrameSaver® SLV 9128/9128-II Network Access Module (NAM) Installation Instructions

Document Number 9128-A2-GN11-50

April 2002

Product Documentation Online

Complete documentation for this product is available at www.paradyne.com.
Select *Library* → *Technical Manuals* → *FrameSaver Frame Relay Devices*.

Select the following document:

9128-A2-GB20

FrameSaver SLV, Models 9126, 9128, and 9128-II, User's Guide

To order a paper copy of a Paradyne document:

- Within the U.S.A., call 1-800-PARADYNE (1-800-727-2396)
- Outside the U.S.A., call 1-727-530-8623

Upgrading a Unit to the SLM Feature Set

Full Service Level Management (SLM) capability can be activated in units that have the basic diagnostic feature set at any time. This is an optional feature that adds real-time and historical network performance monitoring and SLA (Service Level Agreement) reporting capabilities to your FrameSaver unit and network. Simply order a Feature Activation Certificate and provide the model to be activated, your OpenLane® SLM system license key number, and the number of FrameSaver units to be activated to SLM capability. You can order the certificate for a single unit or for many units.

OpenLane SLM Release 5.3 or above is required to schedule activation of SLM features in units, and to manage the number of activations remaining on the certificate. OpenLane also provides a Certificate Summary Report to assist you in the management of the certificate.

When the Feature Activation Certificate arrives, add the Activation Certificate Number to your OpenLane SLM application's database. Activations can occur at any time, for as many units as desired, until no activations remain for the certificate. When ready to activate units, simply select the units to be activated and schedule the activations. The activations occur when scheduled, and OpenLane updates the certificate information.

Contact your sales representative for additional information.

Package Checklist

Verify that your package contains the following:

- FrameSaver SLV NAM
- NAM I/O card
- T1 network cable
- FrameSaver SLV 9128/9128-II Quick Reference* (Document No. 9128-A2-GL10)

Be sure to register your warranty at www.paradyne.com/warranty.

Preparation

Make sure you have:

- A small flat-blade screwdriver.
- A small Phillips screwdriver.
- FrameSaver SLV ISDN Dial Backup Module (DBM) Installation Instructions* (Document No. 9000-A2-GN19) if installing an ISDN PRI DBM.

If a FrameSaver NAM with DBM is being replaced, the DBM must be transferred to the replacement NAM.

- If desired, an operable Ethernet LAN (Local Area Network) connection for access by an NMS (Network Management System)
- Configuration information for the FrameSaver unit being installed or replaced.
- Appropriate cables:
 - DSX cable
 - Data port cables
 - COM port-to-terminal or COM port-to-PC cable
 - Modem cable
 - ISDN PRI cable, if applicable
 - Ethernet cable, if applicable

See the User's Guide for additional information on:

- Troubleshooting
- Technical Specifications
- Connectors, Cables, and Pin Assignments

Cables You May Need to Order

If connecting to a . . .	Order a . . .	Feature Number
T1 line interface/connector <i>(For use in Canada)</i>	T1 line interface cable, RJ48C-to-CA81A	3100-F1-510
DSX-1 Cable	DSX-1 Adapter Cable 8-Pin modular plug-to-DB15 socket	9008-F1-560

Contact your sales representative to order cables.

Safety Instructions

Please read the [Important Safety Instructions](#) on page 27.

HANDLING PRECAUTIONS FOR STATIC-SENSITIVE DEVICES

This product is designed to protect sensitive components from damage due to electrostatic discharge (ESD) during normal operation. When performing installation procedures, however, take proper static control precautions to prevent damage to equipment. If you are not sure of the proper static control precautions, contact your nearest sales or service representative.



Installing the I/O Card

The NAM's I/O card provides the network, DSX, DBM, modem, DTE, and COM port connections. The I/O card inserts directly behind the NAM that it supports in the access carrier.

► Procedure

1. Remove the I/O card from the shipping box.

To avoid damaging the card, handle by the top and bottom edges only.

2. At the rear of the carrier, align the I/O card with the upper and lower tracks for the slot.

Push gently toward the midplane until it stops and the card cannot be pushed any further.

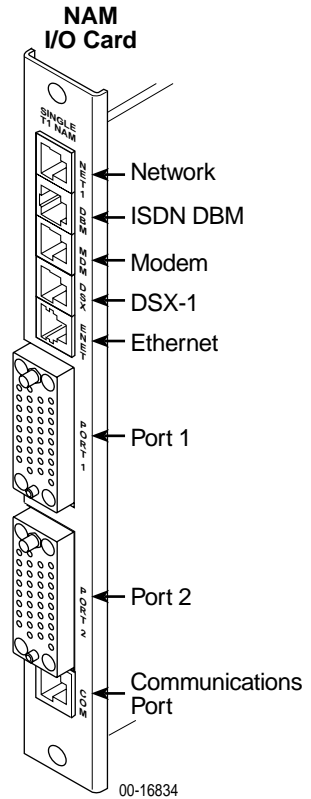
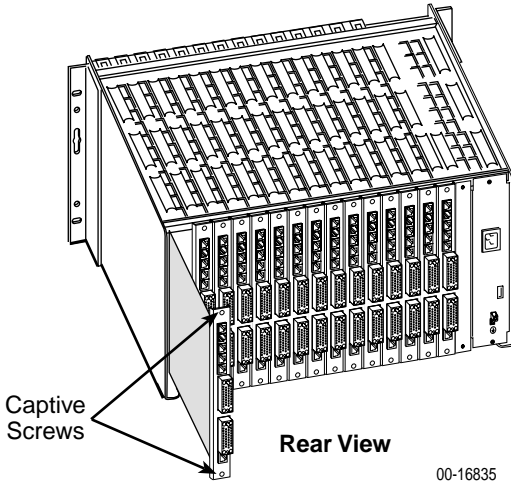

3. Using a small Phillips screwdriver, alternately tighten the captive screws until they are all snug.

NOTE:

The rear panels shown in these instructions are for the Model 9128-II, which has an Ethernet port. Except where noted, installation instructions are the same for the Model 9128 without an Ethernet port.

Installing the NAM into a Multislot Housing

The illustration shows the 14-slot access carrier housing.

CAUTION:

Be sure that you install the NAM in the correct slot so that it mates with its matching I/O card. Otherwise, you could damage your card.

► Procedure

1. Remove the NAM from the shipping box. Handle only by the top and bottom edges to avoid damaging the card.
2. At the front of the carrier, align the NAM with the upper and lower tracks of the appropriate slot.
3. Slide the NAM into the tracks until it seats with the midplane connectors. Use care not to force the card or bend any pins.
4. Close the carrier's upper and lower ejector latches to lock the card into place, then tighten the captive screws on the ejector latches.
5. Check that the OK LED lights.

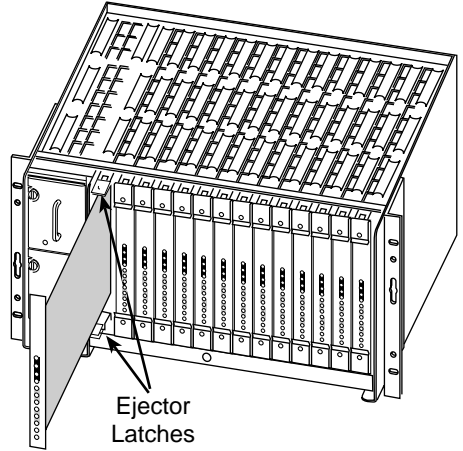

Front View

98-16209

If the OK LED is on, you have power.
If not, refer to *Troubleshooting* in the User's Guide for possible explanations.

Connecting the COM Port to an Asynchronous Terminal

A VT100-compatible asynchronous terminal or a PC providing VT100 terminal emulation must be used to set up access to and management of the unit.

► Procedure

1. Configure the VT100-compatible asynchronous terminal or PC to be compatible with the FrameSaver unit:
 - COM Port in use by your PC is COM1 or COM2.
 - COM Port Baud Rate is set to 19.2 Kbps.
 - Character length is set to 8 data bits.
 - Parity is set to None.
 - Stop bit is set to 1.
 - Flow Control is set to None.
2. Insert the 8-pin end of the cable into the COM port for the appropriate slot.

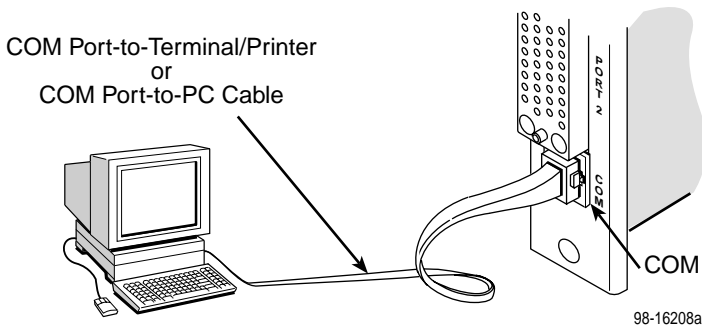

3. Insert the other end of the cable into the terminal or PC.
 4. Press Enter on the keyboard to display the Main Menu.
- If the Main Menu does not appear, recheck the terminal or PC settings (see Step 1), or press the Enter key. Refer to *Troubleshooting* in the User's Guide for other possible explanations.

Verifying that Self-Test Passed

To verify that the unit passed its self-test, go to the System and Test Status screen.

Main Menu → Status → System and Test Status

The results of the self-test appears on the next screen line, under the screen title.

If any failure messages appear, reset the unit by disconnecting, then reconnecting the power cord. The unit will perform the self-test again. If the failure reappears, call your service representative for assistance.

A Quick Guide to Configuration

The FrameSaver unit should operate using the default (factory-set) configuration options, with exception to the changes specified in these installation instructions. Refer to the following table for help in navigating the menus.

Press the . . .	To . . .
Esc key	Go back one screen or menu level. To see a visual representation of the menu levels, see <i>Menu Hierarchy</i> in the Quick Reference.
Tab key, or Up (↑), Down (↓), Left (←) and Right (→) Arrow keys	Move the cursor from one menu item to the next.
Enter or Return key	Complete the menu or option selection.
Spacebar	Display the next available setting when changing a configuration option. All the available settings for an option appears at the bottom of the screen.

As an example, follow these steps to go to the Configuration Edit/Display menu so you can start setting up the unit.

To load a configuration for editing:

1. From the Main Menu, press the down arrow key twice so the cursor is on Configuration.
2. Press Enter to display the Configuration menu. The Load Configuration From menu appears.
3. Press Enter to select Current Configuration (the cursor is already on this selection). The Configuration Edit/Display menu appears.

This sequence of steps would be shown as the menu selection sequence:

Main Menu→*Configuration*

To save a configuration option change:

1. Press Ctrl-a to switch to the function keys area at the bottom of the screen.
2. Type **s** or **S** (Save) and press Enter. The Save Configuration To menu appears.
3. Press Enter again to save your changes to the Current Configuration.
4. Press Esc until the Configuration Edit/Display menu reappears to continue configuring the unit.

Press Ctrl-a, type **m** (MainMenu), and press Enter to return to the Main Menu.

In the sections that follow, only the minimum option changes required are included so you will have a quick and trouble-free installation. See the configuration option tables in the User's Guide for more information about configuration options.

About the Installation Procedures

There are two methods for installing and setting up the FrameSaver unit.

- One person can install and set up the unit. If this is the case, see *Full Installation and Setup*.
- An installer can physically install and set up access to the unit, and the network operation center (NOC) can complete the setup. If this is the case, see *Minimal Installation for Service Providers* on page 11.

Certain procedures are common to both the full installation and minimal methods. These procedures are referenced in the full and minimal installation instructions (starting with *Setting Up Local Management at the Central Site* on page 13). Refer to them, as needed.

Full Installation and Setup

An Easy Install screen is provided to simplify installation and setup. It can be used for the first part of the installation when one person is installing and setting up the unit from beginning to end.

Easy Install Screen Example

```
main/easy_install                               9128-II
Device Name: Node A                             8/18/2000 23:32

                                EASY INSTALL

Node IP Address:           000.000.000.000   Clear
Node Subnet Mask:         000.000.000.000   Clear
TS Access:  DLCI                980

Create a Dedicated Network Management Link
Ethernet Port Options Screen *
Time Slot Assignment Screen

Network 1 Line Framing Format:  ESF
Network 1 Line Build Out (LBO): 0.0
Network 1 Line Coding Format:   B8ZS
DS0 Base Rate (Kbps):  **      Nx64

-----
Ctrl-a to access these functions, ESC for previous menu  MainMenu  Exit
Save
```

* The Ethernet Port Options Screen only applies to the Model 9128-II.

** DS0 Base Rate (Kbps) only applies to the Model 9128.

It is assumed that frame relay service is turned on at the site.

► Procedure

1. Select the Easy Install feature.

Main Menu → Easy Install

2. Enter the Node IP Address and Subnet Mask.
3. Set TS Access to DLCI, then select a DLCI on the network interface that will be used for the troubleshooting access link.
4. Create a Dedicated Network Management Link, selecting a DLCI for the management link at the **which DLCI would you like to Create a Dedicated Network Management Link on?** prompt, which will be used by the NOC to access the unit.
5. For a FrameSaver SLV 9128-II that will use its Ethernet port, select the Ethernet Port Options Screen and configure the following:
 - Enable Interface Status. If the NMS will be on a different subnet than the unit, enter **Yes** at the **would you like to set the Node's Default IP Destination to Ethernet?** prompt. Otherwise, enter **No**.
 - If the IP Address and Subnet Mask are unique to the interface, enter them for the port; otherwise, the Node IP Address and Subnet Mask will be used.
 - Enter the Default Gateway Address; the IP Address that will be used for packets without a route.
 - Enable Proxy ARP if the unit will proxy for downstream FrameSaver units learned via the proprietary RIP (Routing Information Protocol) feature.
 - Press the Esc key to return to the Easy Install screen.
6. Configure the T1 network interface options to match the service provider's settings.
7. Save the configurations.
8. Install the network cable (see [Connecting to the Network](#) on page 18). The FrameSaver unit starts discovering DLCIs and network time slots (see [Automatic Configuration](#) on page 14).

The remaining steps are optional, depending upon the application. They are performed from the Main Menu.

9. If the unit will be enforcing CIR (Committed Information Rate) and EIR (Excess Information Rate) on network frame relay links, enable Traffic Policing.

Main Menu → Configuration → System → Frame Relay and LMI

You can change other Frame Relay and LMI default settings, if necessary.

10. Configure each interface according to the local management interface (LMI) and assigned line conditions supplied by the service provider.

Configuration → Network → Frame Relay
Configuration → Data Ports → Frame Relay

-
11. Set up SNMP local management (see [Setting Up Local Management at the Central Site](#) on page 13).
 12. Set up the modem, and the Call Directories if trap dial-out is desired (see [Setting Up the Modem](#) on page 14).
 13. If the unit is equipped with an ISDN DBM, set up the DBM (see [Setting Up the ISDN DBM](#) on page 16).
 14. If SNMP traps are wanted, set up managers, select the desired traps, and configure trap dial-out if desired (see [Configuring SNMP Trap Managers and Trap Dial-Out](#) on page 18).
 15. Save the configurations.
 16. Verify the entire path from the remote unit to the NMS is functioning (see [Verifying the End-to-End Path](#) on page 20).
 17. If the DSX-1 interface will be used, install the DSX-1 cable (see [Connecting to DSX](#) on page 21). Time slots for the DSX-1 interface will need to be assigned to the network interface (see [Assigning DSX-1 Time Slots to the Network Interface](#) in *Configuration of the User's Guide*).
 18. Install the modem cable (see [Connecting the Modem](#) on page 21).
 19. If the unit is equipped with an ISDN DBM, install the ISDN DBM cable (see [Connecting to ISDN](#) on page 21).
 20. If the FrameSaver SLV 9128-II will use its Ethernet port for management, install the Ethernet cable (see [Connecting to Ethernet](#) on page 22).
 21. Install the DTE cables (see [Connecting to a DTE](#) on page 22).
 22. Verify that data is being received (see [Verifying That Data is Being Received](#) on page 24).
 23. Verify that all PVCs, including Management PVCs, are configured; and see whether the PVC is active or not (see [Checking PVC Connections](#) on page 25).
 24. Verify the setup for backup, if applicable (see [Verifying the ISDN Line and That Data Can Be Passed Between DBMs](#) on page 26).

The FrameSaver installation is complete.

Minimal Installation for Service Providers

In the following procedures, once the unit is installed and minimal configuration is completed using the Easy Install feature, the NOC can complete and verify the setup.

Physically Installing the Unit and Setting Up for Remote Access

It is assumed that frame relay service is turned on at the site. For a FrameSaver SLV 9128-II, this procedure is for setting up the unit in Frame Relay mode; the FrameSaver SLV 9128 is always in Frame Relay mode.

► Procedure

1. Follow Steps 1 through 8 of *Full Installation and Setup* on page 8.
2. If the DSX-1 interface will be used, install the DSX-1 cable (see [Connecting to DSX](#) on page 21).
3. Install the modem cable (see [Connecting the Modem](#) on page 21).
4. If the unit is equipped with an ISDN DBM, install the ISDN DBM cable (see [Connecting to ISDN](#) on page 21).
5. If a FrameSaver SLV 9128-II will use its Ethernet port for management, install the Ethernet cable (see [Connecting to Ethernet](#) on page 22).
6. Install the DTE cables (see [Connecting to a DTE](#) on page 22).

Physical installation of the unit is complete; the NOC can now remotely access the unit for additional configuration.

Completing Setup of the Unit From the NOC

► Procedure

1. Access the remote FrameSaver unit using the dedicated management link, using the Node IP Address that was entered (see [Physically Installing the Unit and Setting Up for Remote Access](#) on page 11).
2. Configure specific frame relay options, like CIR (committed information rate), and any other configuration options requiring input or changes from the default settings.
3. Configure each interface according to the local management interface (LMI) and assigned line conditions supplied by the service provider.
Configuration → Network → Frame Relay
Configuration → Data Ports → Frame Relay
4. If SNMP traps are wanted, set up managers, select the desired traps, and configure trap dial-out if desired (see [Configuring SNMP Trap Managers and Trap Dial-Out](#) on page 18).
5. Set up the modem and, if trap dial-out is desired, the Call Directories (see [Setting Up the Modem](#) on page 14).
6. If the unit is equipped with an ISDN DBM, set up the DBM (see [Setting Up the ISDN DBM](#) on page 16).
7. Save the configurations.
8. Verify the entire path from the remote unit to the NOC NMS is functioning (see [Verifying the End-to-End Path](#) on page 20).
9. Verify that data is being received (see [Verifying That Data is Being Received](#) on page 24).
10. Verify that all PVCs, including Management PVCs, are configured; and see whether the PVC is active or not (see [Checking PVC Connections](#) on page 25).
11. Verify the setup for backup, if applicable (see [Verifying the ISDN Line and That Data Can Be Passed Between DBMs](#) on page 26).

The FrameSaver installation is complete.

Setting Up Local Management at the Central Site

► Procedure

1. Create a DLCI for the data port.

Configuration → Data Ports → DLCI Records

2. Save the configuration.

3. Create a Management PVC using the data port DLCI just created.

Configuration → Management and Communication → Management PVC

Minimally, enter the following options:

- Name for the management PVC
 - Interface IP Address and Subnet Mask, if different from the Node's
 - Primary Link for this Management PVC (the user data port)
 - Primary DLCI (i.e., the data port DLCI)
4. Save the configuration.

Automatic Configuration

The FrameSaver unit provides several automatic configuration features. Frame Relay Discovery and configuration is one of these features.

Main Menu → Auto-Configuration

The default discovery mode is 1MPort. In this mode, for each DLCI discovered on the network, the unit creates a network interface DLCI containing two EDLCIs (embedded DLCIs – one for Port-1 data and the other for management), a Port-1 DLCI with the same number, and a management PVC, then cross-connects them.

NOTE:

When auto-configuration creates a multiplexed DLCI, but a standard DLCI is needed, change the DLCI to Standard from the network DLCI Records screen:
Configuration → Network → DLCI Records

Other modes can be selected. See *Setting Up Automatic Configuration* in *Configuration* of the User's Guide for information about other modes and how the Frame Relay Discovery Mode can be changed.

No automatic configuration occurs until the network cable is connected. If you do not want management links configured or automatic configuration, change the default setting for the Frame Relay Discovery feature.

Time Slot Assignment

Network time slots are discovered automatically when Time Slot Discovery is enabled (the default setting) on the Frame Relay Network 1 Assignments screen. This feature can be disabled if you want to manually configure time slots.

See *Assigning Time Slots/Cross Connections* in *Configuration* of the User's Guide for additional information about this feature.

Setting Up the Modem

The unit has an integral modem for remote management. It is already set up for dial-in access to the unit, with Port Use set to Terminal.

► Procedure

If using the modem for dialed IP network connectivity (SNMP, Telnet, FTP, or trap dial-out):

1. Select Modem Port.

Configuration → Management and Communication → Modem Port

2. Minimally, change Port Use to Net Link, and assign the interface's IP Address and Subnet Mask if it is different from the Node's. Change Link Protocol to SLIP, if necessary (PPP is the default setting).
3. Save the configuration.

Setting Up Call Directories if Trap Dial-Out Is Desired

► Procedure

1. Set up directory phone numbers.

Main Menu → Control → Modem Call Directories

2. Select Directory Number A (for Alarm).
3. Enter the phone number(s). Valid characters include:
 - ASCII text
 - B for blind dialing
 - W for wait for dial tone
 - P for pulse dialing unless B specified
 - T for tone dialing unless B specified
 - Space, underscore (_), comma (,) for a 2-second pause, and dash (-) readability characters
4. Save the phone number(s).

Setting Up to Use the Modem PassThru Feature

The Modem PassThru feature allows access to the router via a dial-up connection to the unit. When this feature is set up and active, a logical connection between the unit's modem and COM ports is made, and data received over the modem port is transmitted out the COM port to the router's auxiliary (AUX) serial port. When an escape sequence (minus, minus, minus) is detected, the FrameSaver unit switches back to normal user interface operation. If this feature will be used, the COM port must be configured for that use.

► Procedure

1. Configure the COM port to use Modem PassThru.

Main Menu → Configuration → Management and Communication → Communication Port

2. Set Port Use to Modem PassThru.
3. Save the configuration.

Setting Up the ISDN DBM

FrameSaver SLV 9128s and 9128-IIs may be equipped with an ISDN PRI DBM. These instructions are for units with ISDN backup capability.

The following guidelines apply:

- **Central site** configuration guidelines:
 - Set up the ISDN DBM physical interface.
 - Modify the Link Profile(s) that Automatic Backup Configuration created to add a phone number.
 - Configure the unit to answer calls from the remote sites. (A PRI DBM is already configured to answer calls.)
- **Remote site** configuration guidelines:
 - Set up the ISDN DBM physical interface.
 - Change the Automatic Backup Configuration to `Single_Site_Backup`.
 - Modify the `HQ_Site` Link Profile that Automatic Backup Configuration created to add a phone number.
 - Configure the remote unit to originate calls to the central site.
 - Set the criteria by which automatic backup will take place.

Setting Up the DBM Physical Interface

► Procedure

1. Configure the DBM interface.
Main Menu → Configuration → ISDN → Physical
2. Minimally, set the following configuration options:
 - Interface Status is set to Enable.
 - T1 physical characteristics are configured to match the service provider's settings.
 - Local Phone Number 1 is entered.
 - Maximum Link Rate is selected.
3. Save the configuration and return to the ISDN menu.

Setting Up Automatic Backup Configuration

The Automatic Backup Configuration feature, included on the Auto-Configuration menu, is used to automatically create alternate DLCI records and PVC connections on the ISDN DBM (backup) interface. A PRI DBM is set up for `Multi_Site_Backup`.

See the User's Guide for additional information.

Modifying ISDN Link Profiles

► Procedure

1. Select Link Profiles, then Modify.

The FrameSaver unit automatically configures an ISDN Link Profile on the first ISDN link, with HQ_Site as the Link Name. For subsequent ISDN Link Profiles, select New.

2. Add a name and phone number to the ISDN Link Profile(s) created by Automatic Backup Configuration.
 - Name for the destination entered (e.g., Tampa). The default setting is HQ_Site.
 - Phone numbers entered:

For Originating a Backup Call	For Answering a Backup Call
Outbound and Alternate Outbound phone numbers Valid characters include: <ul style="list-style-type: none">■ Numbers (0–9)■ Special characters * and #■ Spaces■ Parentheses ()■ Transmit Timing	Inbound Calling ID1 and ID2 These are the phone numbers of units from which calls will be accepted. Valid characters include: <ul style="list-style-type: none">■ Numbers (0–9)

NOTES:

Remember to include local dial-out numbers (i.e., 9, then the number).

For every originating (outbound) phone number entered, an answering (inbound) phone number must be entered at the far end, and vice versa.

- Maximum Link Rate is changed, if necessary. The default setting is 64 Kbps.
3. Save the configuration.

Setting the Criteria for Automatic Backup

► Procedure

1. Enable Auto Backup.

Main Menu → Configuration → Auto Backup Criteria

When a failure occurs, the unit automatically enables the Alternate Link and traffic is rerouted over the backup (alternate) interface.

2. Specify When Auto Backup Allowed – Always or Restrict. If Restrict is selected, specify the days and hours of the week during which automatic backup can take place.
3. Save the configuration.

Configuring SNMP Trap Managers and Trap Dial-Out

Once the FrameSaver unit is connected to the network, SNMP trap managers, SNMP traps, and trap dial-out can be configured.

► Procedure

1. Select SNMP Traps.

Main Menu → Configuration → Management and Communication → SNMP Traps

2. Configure the following:
 - Enable SNMP Traps.
 - Identify the total Number of Trap Managers.
 - Specify the IP address of the NMS(s) to which traps will be sent.
 - Specify the network Destination for the Trap Manager(s).
 - Select desired trap categories.
 - Enable Trap Dial-Out, if desired.
3. Save the configuration.
4. Return to the Main Menu.

Connecting to the Network

► Procedure

1. Insert the 8-pin connector on the RJ48C network cable into the NET interface.
2. Insert the other end of the cable into the RJ48C modular jack.

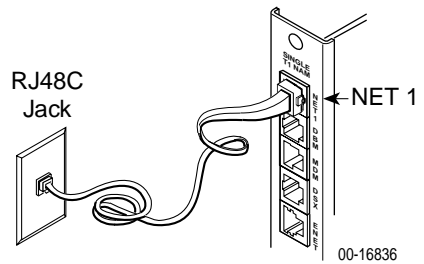

3. Verify that the Network signal (SIG) LED is green, and that the Network out-of-frame (OOF) and alarm (ALM) LEDs are off. If so, the network interface is set up correctly and is operational. If not, make sure both ends of the network cable are properly seated.

The FrameSaver SLV 9128-II has a FR (Frame Relay) LED. It will be green when LMI is up and yellow when LMI is down.

4. Check Health and Status messages in the left column of the System and Test Status screen.

Main Menu → Status → System and Test Status

If **LMI Down**, **Network** appears for more than three minutes, or any other network-related status message appears, refer to the status information in *Operation and Maintenance* of the User's Guide for possible reasons for the messages and what can be done to resolve the problem.

If the unit does not have ISDN backup capability, proceed to [Configuring SNMP Trap Managers and Trap Dial-Out](#).

Connecting to an M66 Block

Use the optional T1 mass termination cable to connect up to seven NAMs to an M66 block. The T1 mass termination cable is a 5-foot RJ48H cable consisting of a 50-pin plug-to-seven RJ48C plugs.

► Procedure

1. Insert RJ48C plugs on the RJ48H network cable into up to seven FrameSaver unit NET interface(s).
2. Insert the 50-pin plug end of the cable into the M66 block.
3. Follow Steps 3 and 4 in [Connecting to the Network](#) on page 18 to verify the connection.

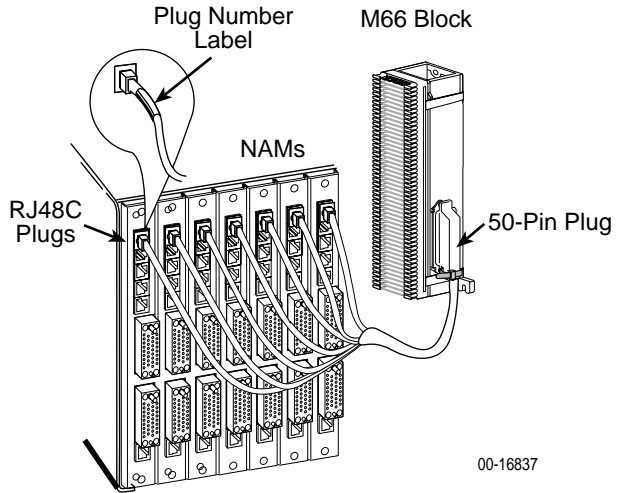

00-16837

Verifying the End-to-End Path

After installation of a remote site unit, run an IP Ping test to ping the NMS at the central site and verify that the entire path from the remote unit to the NMS is functioning. To run the IP Ping test, NMS trap managers must have been configured for the remote unit. One of those trap managers must be the central site NMS.

► Procedure

1. Select the IP Ping test.

Main Menu → Test → IP Ping

2. Enter the IP Address of the device being pinged, then select Start.

NOTE:

When running tests, the cursor is positioned over the Start command. Press Enter to start the test. `stop` is displayed while the test is running. Press Enter again to issue the Stop command.

- While the test is running, **In Progress...** appears in the Status field.
- When the test is finished, **Alive. Latency = nn ms** should appear as the Status (*nn* being the amount of time the test took in milliseconds).

If any other message is displayed, additional testing will be required. See *Device Messages in Operation and Maintenance* of the User's Guide for information about IP Ping-related messages.

Connecting to ISDN

► Procedure

1. Insert the 8-pin connector on the ISDN cable into the DBM interface.
2. Insert the other end of the cable into the ISDN service RJ48C jack.

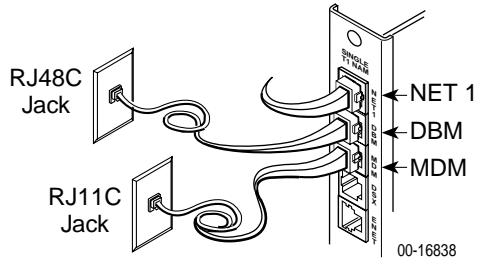

Connecting the Modem

► Procedure

1. Insert the 6-pin connector on the modem cable into the MDM interface.
2. Insert the other end of the cable into the modem service RJ11C jack.

Connecting to DSX

► Procedure

1. Insert the 8-pin connector on the DSX cable into the DSX interface. If your DSX cable has a DB15 end, use a DSX-1 adapter cable.
2. Insert the other end of the cable into the CPE (Customer Premises Equipment, such as a PBX).

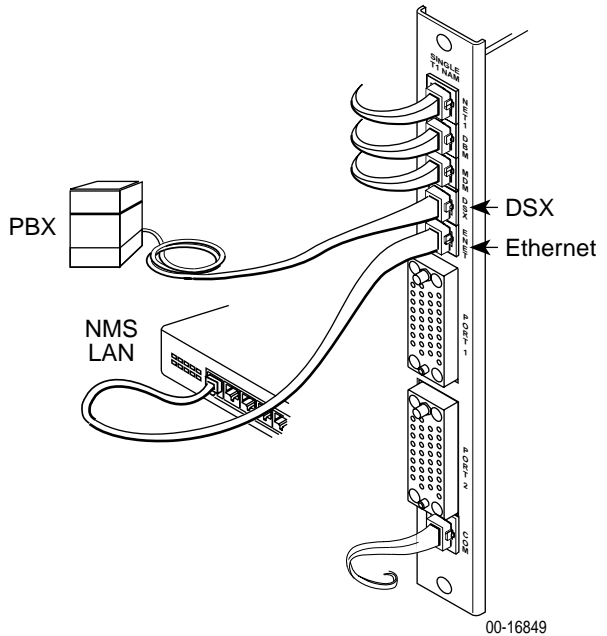

Connecting to Ethernet

► Procedure

1. Insert one 8-pin connector of the Ethernet cable into the Ethernet port.
2. Insert the other end of the cable into the Ethernet interface of the LAN where the NMS resides.

Connecting to a DTE

► Procedure

1. Connect one end of the V.35 cable to Port 1 or Port 2.
2. Connect the other end of the V.35 cable to the DTE.

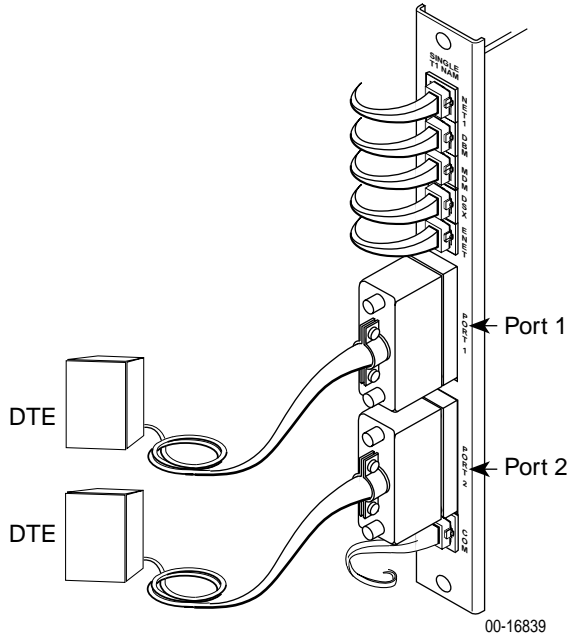

Verifying Connections and Setup

Check the modem, DSX, Ethernet, DTE, and PVC connections, as well as the ISDN DBM setup if a DBM is installed.

Checking the Modem Connection

► Procedure

If Port Use is set to Terminal (dial-in access):

1. Dial the modem's phone number using a remote asynchronous terminal or PC.
2. Verify that the Main Menu appears.

If Port Use is set to Net Link (SNMP, Telnet, FTP, and trap dial-out):

1. Dial the modem's phone number using a PC running PPP or SLIP link protocol.
2. From the PC, run an IP Ping test to the modem interface.

If your results using either method are unsuccessful, make sure both ends of the modem cable are properly seated and secured. Then, verify that the modem was configured correctly (see [Setting Up the Modem](#) on page 14). Otherwise, refer to the status information in *Operation and Maintenance* of the User's Guide.

Checking the DSX Connection

► Procedure

1. Verify that the DSX signal (SIG) LED is green, and that the DSX out-of-frame (OOF) and alarm (ALM) LEDs are off. If so, the DSX interface is set up correctly and is operational. If not, make sure both ends of the DSX cable are properly seated.

When ALM is on, contact the service provider.

2. Check Health and Status messages in the left column of the System and Test Status screen.

Main Menu → Status → System and Test Status

If any DSX-1 messages appear, refer to the status information in *Operation and Maintenance* of the User's Guide.

Checking the Ethernet Connection

Check Health and Status messages in the left column of the System and Test Status screen to verify that there are no Ethernet-related Health and Status messages.

Main Menu → Status → System and Test Status

If the **Ethernet Link Down** message appears, make sure both ends of the Ethernet cable are properly seated.

Checking the DTE Connection

Perform these checks for both user data ports.

► Procedure

1. Verify that the Port OK LED is on. If not, make sure both ends of the cable are properly seated and secured. Then, check the DTE; RTS or DTR could be down on the DTE.
 - The FrameSaver SLV 9128 has a Port OK LED for each port.
 - The FrameSaver SLV 9128-II has one Port OK LED for both ports. If either port is enabled and active, the LED is on. If both ports are enabled and one of the ports is inactive, the LED is off.
2. Check Health and Status messages in the left column of the System and Test Status screen for messages.

Main Menu → Status → System and Test Status

- If **system Operational** appears, the port interface is set up correctly and is operational.
- If not, refer to *Status Information* in the User's Guide.

NOTE:

When any error conditions are detected, a status message appears along the bottom right corner of the screen.

Verifying That Data is Being Received

► Procedure

1. Return to the Main Menu, then select Status.
2. Select Performance Statistics, and select an interface's frame relay statistics (e.g., Network Frame Relay).

Main Menu → Status → Performance Statistics → Network Frame Relay
3. Clear the statistics and see whether the counts for Frames Received and Characters Received under the Frame Relay Link are incrementing, and verify that there are no errors under the Frame Relay LMI statistics. Refresh the screen to update the counts.
 - If data is being received, the count increments after refreshing the screen.
 - If data is not being received, recheck the cable connections, and replace or repair a damaged cable. Recheck LMI status; you may need to contact your service provider. Next, check the DLCI's status.

Checking PVC Connections

Check PVC connections to verify that all PVCs, including management PVCs, are configured, and to see whether the PVC is active or not.

► Procedure

1. Press Esc to return to the Status menu.
2. Select PVC Connection Status.

The PVC Connection Status screen shows all PVC connections; the interface and DLCI number of the source interface and DLCI number for the destination interface. You can also see whether the PVC is active.

3. Verify that each PVC is active.
 - If active, the FrameSaver unit should be passing data.
 - If not active, no data traffic can be carried by the PVC. If the PVC is configured correctly, the circuit may be down.

Verifying the ISDN Line and That Data Can Be Passed Between DBMs

► Procedure

1. Verify the ISDN line by checking the DBM Interface Status.

Main Menu → Status → DBM Interface Status

Line Status should be Active. If an invalid (Inv) status is displayed, verify that you entered ISDN physical options correctly.

2. Check backup setup and that data can be passed between DBMs.

- Select Test, then ISDN Call/PVC Tests

Main Menu → Test → ISDN Call/PVC Tests

- Select the link to be tested.
- Start a Test Call. The Status should be Active.
- Wait as the originating DBM places the backup call. The originating unit's Test LED is on.

If the Result is . . .	Then . . .
Frame Relay Link Up	The call was successful.
Frame Relay Link Suboptimal	Not all links have come up. Verify that the Maximum Link Rate (Kbps) setting in the ISDN Link Profile is the same at both ends.
Frame Relay Link Down	The call was unsuccessful. Verify the configuration and Link Status in the ISDN Link Profile.

- Select Stop to end the Test Call.

See *Verifying Backup Setup in Configuration* of the User's Guide for additional information.

Connecting the COM Port to the Router

If the Modem PassThru feature will be used, the terminal or PC must be disconnected and the COM port connected to the router's AUX port. A standard cable can be used. See *Connectors, Cables, and Pin Assignments* in the User's Guide for additional information.

⚠ Important Safety Instructions

1. Read and follow all warning notices and instructions marked on the product or included in the manual.
2. If installed in a carrier with an AC power supply, this product is intended to be used with a 3-wire grounding type plug – a plug which has a grounding pin. This is a safety feature. Equipment grounding is vital to ensure safe operation. Do not defeat the purpose of the grounding type plug by modifying the plug or using an adapter.

Prior to installation, use an outlet tester or a voltmeter to check the ac receptacle for the presence of earth ground. If the receptacle is not properly grounded, the installation must not continue until a qualified electrician has corrected the problem.

If a 3-wire grounding type power source is not available, consult a qualified electrician to determine another method of grounding the equipment.

3. If installed in a carrier with a DC power supply, this product is intended to be used in a restricted access location. Connect the product to a –48 VDC SELV (Safety Extra Low Voltage) supply source that is electronically isolated from the AC source. The –48 VDC source is to be reliably connected to earth. Connect the earthing (grounding) conductor to the protective earthing (grounding) lug connector, identified by the protective earth symbol. This is a safety feature. Equipment grounding is vital to ensure safe operation.

Prior to installation, use a voltmeter/ohmmeter to check the wiring for the presence of earth ground. If the wiring is not properly grounded, the installation must not continue until a qualified electrician has corrected the problem.

A readily accessible disconnect device as part of the building installation shall be incorporated into the fixed wiring. The disconnect device (a –48 VDC, 15 or 20A circuit breaker or switch) must be included in the ungrounded supply conductor. Overcurrent protection must be a 15 or 20A, –48 VDC fuse or circuit breaker.

This product is to be installed only in a Restricted Access Location (dedicated equipment rooms, equipment closets, or the like) in accordance with articles 110-16, 110-17 and 110-18 of the National Electrical Code, ANSI/NFPA 70, and articles 2-308, 2-310, 2-312, 2-314, 2-200, and 2-202 of the Canadian Electrical Code.

The rear I/O panel has provision for a permanently connected protective earthing (grounding) conductor. Connect a 6–14 AWG conductor to this solderless lug connector, identified by the protective earth symbol.

4. Slots and openings in the cabinet are provided for ventilation. To ensure reliable operation of the product and to protect it from overheating, these slots and openings must not be blocked or covered.
5. Do not allow anything to rest on the power cord and do not locate the product where persons will walk on the power cord.
6. Do not attempt to service this product yourself, as opening or removing covers may expose you to dangerous high voltage points or other risks. Refer all servicing to qualified service personnel.

-
7. General purpose cables are provided with this product. A UL Listed/CSA Certified, minimum No. 26 AWG, telecommunications cable is provided for connection to the network. Use this cable to reduce the risk of fire.

Special cables, which may be required by the regulatory inspection authority for the installation site, are the responsibility of the customer.

8. When installed in the final configuration, the product must comply with the applicable Safety Standards and regulatory requirements of the country in which it is installed. If necessary, consult with the appropriate regulatory agencies and inspection authorities to ensure compliance.
9. A rare phenomenon can create a voltage potential between the earth grounds of two or more buildings. If products installed in separate buildings are **interconnected**, the voltage potential may cause a hazardous condition. Consult a qualified electrical consultant to determine whether or not this phenomenon exists and, if necessary, implement corrective action prior to interconnecting the products.
10. In addition, if the equipment is to be used with telecommunications circuits, take the following precautions:
- Never install telephone wiring during a lightning storm.
 - Never install telephone jacks in wet locations unless the jack is specifically designed for wet locations.
 - Never touch uninsulated telephone wires or terminals unless the telephone line has been disconnected at the network interface.
 - Use caution when installing or modifying telephone lines.
 - Avoid using a telephone (other than a cordless type) during an electrical storm. There may be a remote risk of electric shock from lightning.
 - Do not use the telephone to report a gas leak in the vicinity of the leak.
11. To reduce the risk of fire, this component card cage must be installed in a suitable Electrical and Fire Enclosure that complies with enclosure, mounting, casualty and segregation requirements of the end-use product. Openings located within the enclosure must be separated from any network-connected component by a minimum of 25 millimeters of air when measured in any dimension, unless the openings are 5 millimeters or less, or measure one millimeter in length, regardless of the width.

EMI Notices

UNITED STATES – EMI NOTICE:

This equipment has been tested and found to comply with the limits for a Class A digital device, pursuant to Part 15 of the FCC rules. These limits are designed to provide reasonable protection against harmful interference when the equipment is operated in a commercial environment. This equipment generates, uses, and can radiate radio frequency energy and, if not installed and used in accordance with the instruction manual, may cause harmful interference to radio communications. Operation of this equipment in a residential area is likely to cause harmful interference, in which case, the user will be required to correct the interference at his own expense.

The authority to operate this equipment is conditioned by the requirements that no modifications will be made to the equipment unless the changes or modifications are expressly approved by Paradyne.

In order to maintain compliance with FCC limits, any supplied ferrite chokes must be installed in accordance with the card installation instructions.

CANADA – EMI NOTICE:

This Class A digital apparatus meets all requirements of the Canadian interference-causing equipment regulations.

Cet appareil numérique de la classe A respecte toutes les exigences du règlement sur le matériel brouilleur du Canada.

Government Requirements

Certain governments require that instructions pertaining to connection to the telephone network be included in the user documentation. Specific instructions are listed in the following sections.

United States

Notice to Users of the Telephone Network

This equipment complies with Part 68 of the FCC rules. On the back of the housing is a label that contains, among other information, the FCC registration number and ringer equivalence number (REN) for this equipment. If requested, please provide this information to your telephone company.

The REN is used to determine the number of devices that may be connected to the telephone line. Excessive RENs on the line may result in the devices not ringing in response to an incoming call. In most, but not all areas, the sum of RENs should not exceed five (5.0). To be certain of the number of devices that can be connected to the line, as determined by the total RENs, contact the local telephone company.

If your unit causes harm to the telephone network, the telephone company may discontinue your service temporarily. If possible, they will notify you in advance. But if advance notice is not practical, you will be notified as soon as possible. You will be advised of your right to file a complaint with the FCC.

Your telephone company may make changes in facilities, equipment, operations, or procedures that could affect the proper operation of your equipment. If so, you will be given advance notice so as to give you an opportunity to maintain uninterrupted service.

No repairs may be performed by the user. Should you experience difficulty with this equipment, refer to the [Warranty, Sales, Service, and Training Information](#) on page 32.

Make the T1 network connection using a Universal Service Order Code (USOC) type RJ48C jack for single-line installations and type RJ48H jack for multiline installations. Specify both the Service Order Code 6.0F, as well as the proper Facility Interface Code, to the telephone company when ordering the T1 line. The T1 equipment can be configured to support any of the framing format and line signaling techniques shown in the table below. The T1 equipment's configuration must correspond to the T1 line's parameters.

T1 Facility Interface Codes

Interface Code	Description
04DU9-BN	1.544 Mbps superframe format (SF) without line power
04DU9-DN	1.544 Mbps SF and B8ZS without line power
04DU9-1KN	1.544 Mbps ANSI ESF without line power
04DU-1SN	1.544 Mbps ANSI ESF and B8ZS without line power

When the unit has an ISDN PRI DBM, make the ISDN PRI connection using a USOC-type RJ48C jack. When ordering an ISDN line from the telephone company, specify the following:

- Service Order Code 6.0F
- Facility Interface Code 04DU-1SN
- Up to 23B Service for an ISDN PRI DBM – Supports up to 23 circuit-switched B-channels, with one local phone number for the entire T1 network connection.
- Circuit Switched Data capability should be specified.

Make the modem connection using a USOC-type RJ11C jack. The modem cannot be used on public coin phone service provided by the telephone company. Connection to party-line service is subject to state tariffs. Contact the state public utility commission, public service commission, or corporation commission for tariff information.

After the telephone company has installed the requested services and jacks, you can connect the unit with the cable provided. An FCC-compliant telephone cord and modular plug are provided with this equipment. This equipment is designed to be connected to the telephone network or premises wiring using a compatible modular jack that is Part 68 compliant.

Canada

Notice to Users of the Canadian Telephone Network

The Industry Canada label identifies certified equipment. This certification means that the equipment meets telecommunications network protective, operational and safety requirements as prescribed in the appropriate Terminal Equipment Technical Requirements document(s). The Department does not guarantee the equipment will operate to the user's satisfaction.

Before installing this equipment, users should ensure that it is permissible to be connected to the facilities of the local telecommunications company. The equipment must also be installed using an acceptable method of connection. The customer should be aware that compliance with the above conditions may not prevent degradation of service in some situations.

Repairs to certified equipment should be coordinated by a representative designated by the supplier. Any repairs or alterations made by the user to this equipment, or equipment malfunctions, may give the telecommunications company cause to request to disconnect the equipment.

Users should ensure for their own protection that the electrical ground connections of the power utility, telephone lines and internal metallic water pipe system, if present, are connected together. This precaution may be particularly important in rural areas.

CAUTION:

Users should not attempt to make such connections themselves, but should contact the appropriate electric inspection authority, or electrician, as appropriate.

The Ringer Equivalence Number (REN) assigned to each terminal device provides an indication of the maximum number of terminals allowed to be connected to a telephone interface. The termination on an interface may consist of any combination of devices subject only to the requirement that the sum of the Ringer Equivalence Numbers of all the devices does not exceed 5.

If your equipment is in need of repair, refer to [Warranty, Sales, Service, and Training Information](#) on page 32.

Warranty, Sales, Service, and Training Information

Contact your local sales representative, service representative, or distributor directly for any help needed. For additional information concerning warranty, sales, service, repair, installation, documentation, training, distributor locations, or Paradyne worldwide office locations, use one of the following methods:

- **Internet:** Visit the Paradyne World Wide Web site at www.paradyne.com. (Be sure to register your warranty at www.paradyne.com/warranty.)
- **Telephone:** Call our automated system to receive current information by fax or to speak with a company representative.
 - Within the U.S.A., call 1-800-870-2221
 - Outside the U.S.A., call 1-727-530-2340

Document Feedback

We welcome your comments and suggestions about this document. Please mail them to Technical Publications, Paradyne Corporation, 8545 126th Ave. N., Largo, FL 33773, or send e-mail to userdoc@paradyne.com. Include the number and title of this document in your correspondence. Please include your name and phone number if you are willing to provide additional clarification.

Trademarks

FrameSaver is a registered trademark of Paradyne Corporation. All other products and services mentioned herein are the trademarks, service marks, registered trademarks, or registered service marks of their respective owners.

Patent Notification

FrameSaver products are protected by U.S. Patents: 5,550,700 and 5,654,966. Other U.S. patents pending.



9128-A2-GN11-50